

## ADA Tray

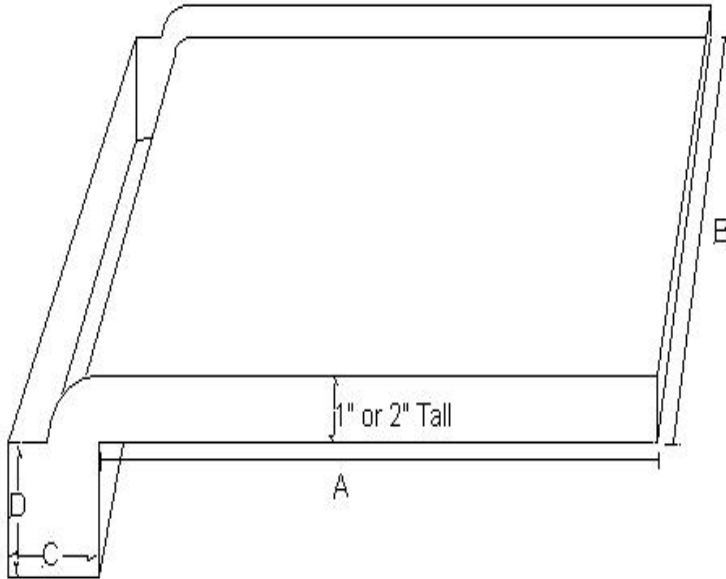

- Protects cabinets and shelving from acid spills
- Over 125 sizes of trays available
- Available in 1", 1-1/2" & 2" depths
- Standard color is natural, special colors available
- 3/16" tray walls for rigidity
- One-piece, rotationally molded polyolefin
- Rounded corners for easy cleaning
- Dishwasher safe
- Non-standard sizes available in 1" increments

Item Number	A	B	C	D

**Specifications:** Laboratory trays or shelf liners shall be a minimum of 3/16" thick, one piece, stress free, molded of virgin polyolefin resins with smooth interior walls and covered corners for easy cleaning. Laboratory trays and shelf liners shall conform to ASTM #1412-92 for corrosion resistance and material content and shall be manufactured by Scientific Plastics, Inc. of Kansas City, KS.