

Dilution Tanks (Plaster or Sedimentation Trap)

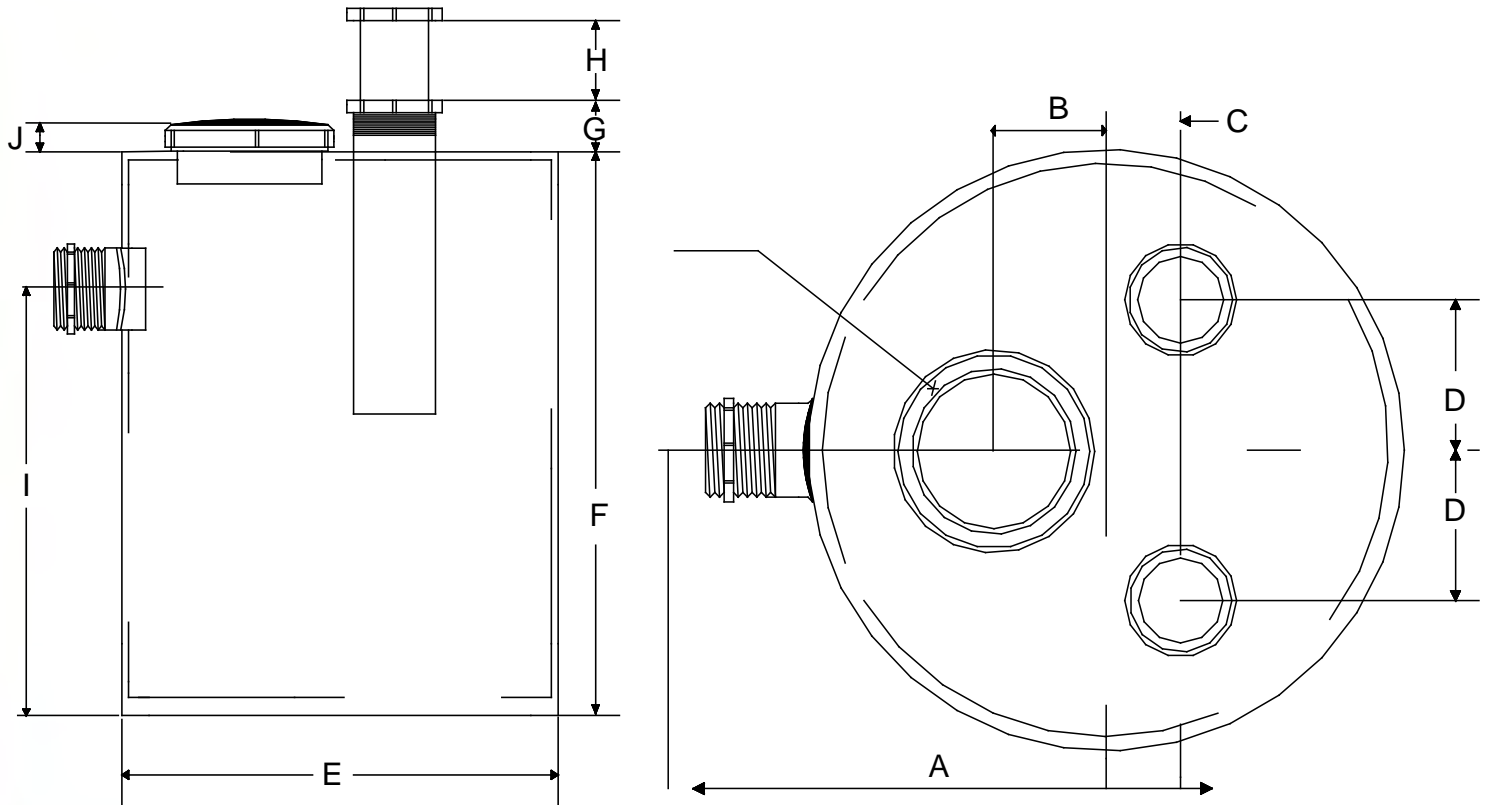

SYMBOL	A	B	C	D	E	F	G	H	I	J	INLET	# OF INLETS	OUTLET
W59155-200	7.31"	2.50"	1.19"	2.06"	9.00"	10.16"	1.91"	0" TO 10"	6.78"		1-1/2"	2	2"
W59155-201	7.31"	2.50"	1.19"	2.06"	9.00"	10.16"	1.91"	0" TO 10"	6.78"	1.64"	1-1/2"	1	2"
W59155-202	7.31"	2.50"	1.19"	2.06"	9.00"	10.16"	1.91"	0" TO 10"	6.78"	1.64"	2	1	2"
W59155-203	7.31"	2.50"	1.19"	2.06"	9.00"	10.16"	1.91"	0" TO 10"	6.78"	1.64"	2	2	2"

1-1/2 Gallon Dilution Tank is designed for dilution or to trap solids for recovery or disposal. Its squat design makes it ideal where bench height is limited. Can be used for single sink or series of sinks. Comes with 2" outlet and adapter to 1-1/2", plus cleanout cap. Available in black and translucent white (White is part #59156, please specify with order). NOTE: Can be used for effluent sampling.